

PARTS SHOULD REFLECT A LEFT AND RIGHT ASSEMBLY

THIS SCREW IS PRE-SET FOR PROPER BEARING PRE-LOAD. DO NOT REMOVE. IF REMOVED, ADJUST SCREW TO ALLOW SMOOTH BEARING ROTATION. IF SET TOO TIGHT, BEARINGS WILL BIND. USE THREADLOCK ON SCREW THREADS.

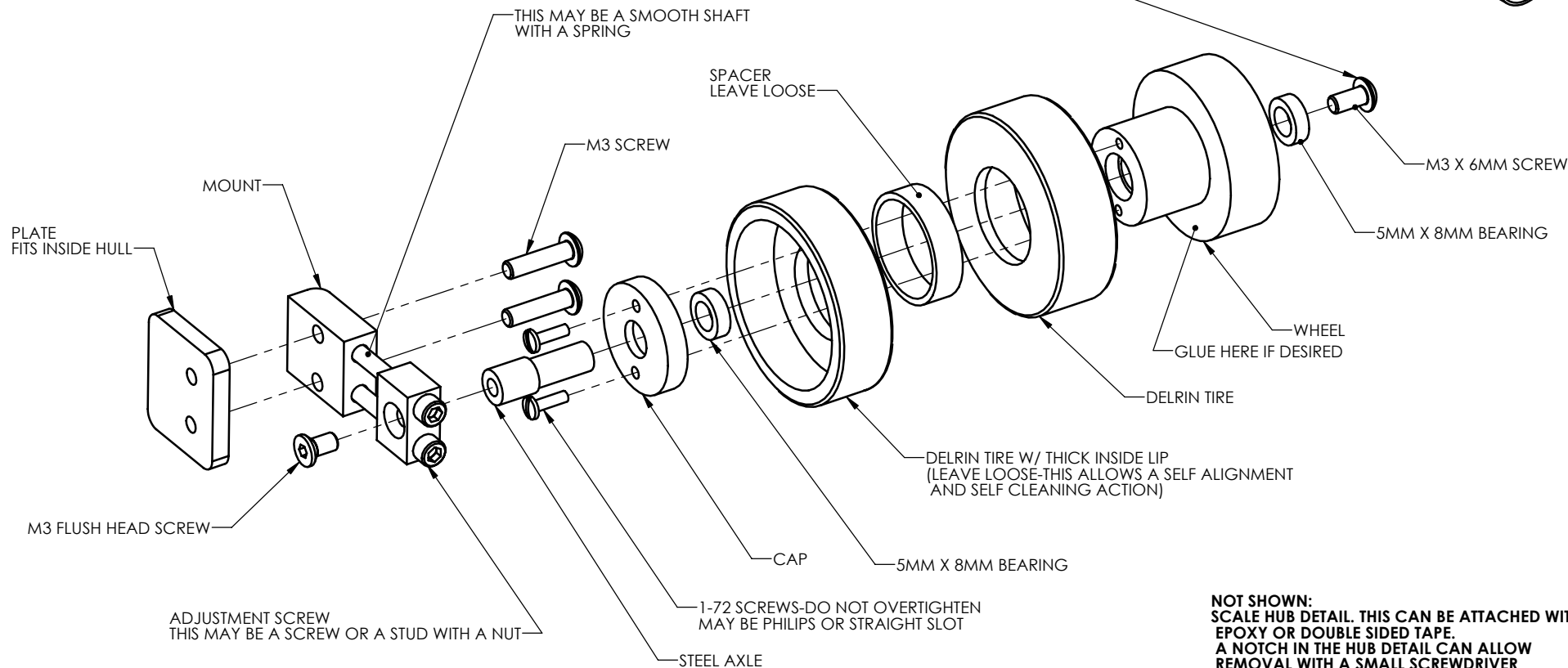

**NOT SHOWN:
SCALE HUB DETAIL. THIS CAN BE ATTACHED WITH
EPOXY OR DOUBLE SIDED TAPE.
A NOTCH IN THE HUB CAN ALLOW
REMOVAL WITH A SMALL SCREWDRIVER**

		DESCRIPTION		SHERMAN IDLER BLOW-UP	
		MATERIAL			
		FINISH			
		DRAWING NO.	REV.	PART NUMBER	
		DRAWN BY		DATE	SIZE
		DBT		8-28-06	C
REV	DESCRIPTION	APPR.	DATE	DO NOT SCALE	SHEET 1 OF 1